

Please verify the contents of the packages!
Please read instructions entirely before starting installation
Be sure power is turned off before installing or modifying the system
Call Tivoli, LLC tech support with questions
Caution: Eclipse™ Wall Light is designed to work with listed **Class 2 12V DC transformers only.** Use of any other power source will cause damage, shorten the life of the fixture and void the warranty.
Consult any and all applicable local and national codes for installation.
Do not conceal or extend exposed conductors through a building wall as per local electrical code.
Warning: With any luminaire for any application, basic safety precautions should always be followed to reduce the risk of fire, electric shock and personal injuries. This lighting system should be installed by a certified professional.

PATENT PENDING



Installation Instructions

Overview

Eclipse™ Wall Light is delivered in 4' and 8' lengths and may be cut to size in the field. Trim Base and Shield to fit location. The Titanium™ LED module strand is shipped pre-assembled in the Shield. Cut off modules to fit if Shield is field cut (See Page 6). Bullet Connectors are provided to re-connect wire that has been cut in the field. Use Joiner Covers to join Eclipse sections together (See Page 4). Conduit and junction boxes should already be in place in wall before installing Eclipse™ Lighting System. See Wiring options on Page 5.

Note: For pony walls, it is recommended that power be run to the lower end of the fixture.

Important: Become familiar with the spacing requirements for each type of Joiner Cover before starting installation. See Spacing Requirements section on Page 3 for detailed information.

Installing over Carpet

When installing Eclipse™ Lighting System over a wall with carpet, be sure the carpet is securely attached to the wall, with no sagging or scalloping. Carpet that is not secured evenly will result in uneven illumination.

WARNING! Damage to Fixture.

When installing Eclipse™ over carpet, carpet must be even and smooth on wall, or fixture may not install evenly, resulting in unsatisfactory illumination and damage to fixture base may result.

If a second layer of carpet is used, Install Eclipse™ Base over first layer of wall carpeting. Then, install the second layer of carpet after Eclipse™ Base is in position and has been securely fastened to wall. See Base Installation instructions. Position the second layer of carpet behind the reflector portion of the Base, as shown.

Note regarding Fasteners:

1 1/2" Walldog fasteners are provided for installation into drywall and wood. Occasionally, a mounting surface will require metal screws. Self-Drilling Metal Screws are available from Tivoli® as an option. Request Part Number **TM-2-3/8**.

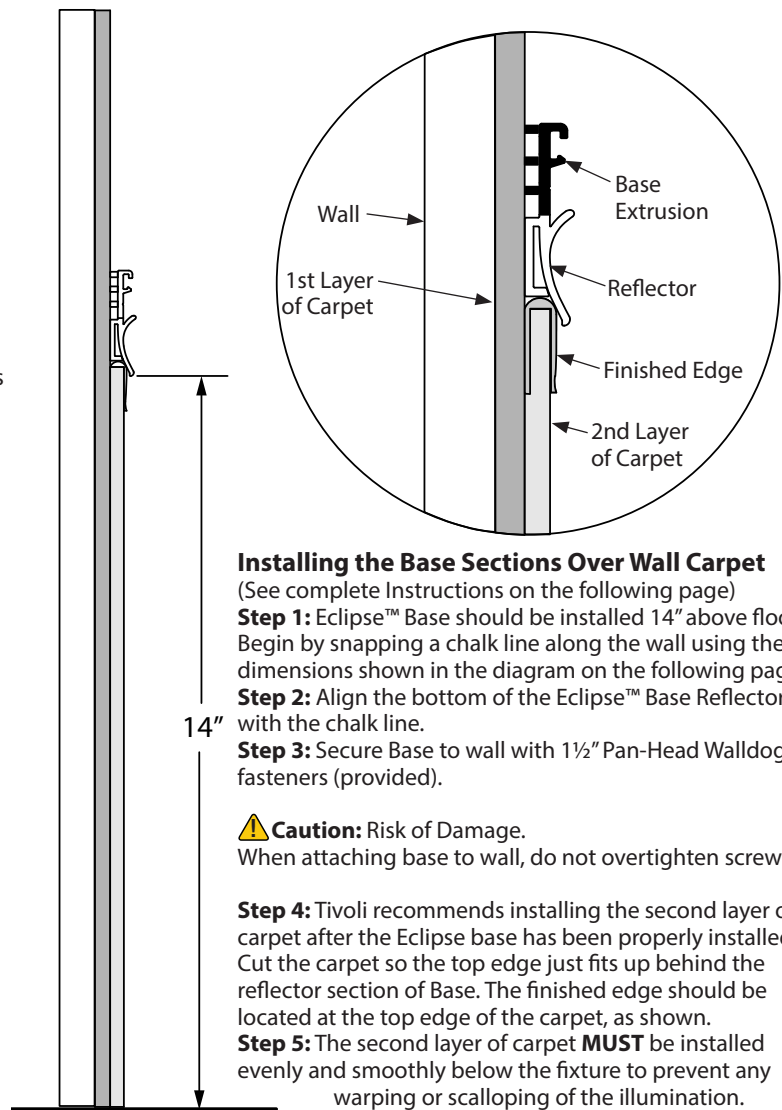

Installing the Base Sections Over Wall Carpet

(See complete Instructions on the following page)

Step 1: Eclipse™ Base should be installed 14" above floor. Begin by snapping a chalk line along the wall using the dimensions shown in the diagram on the following page.

Step 2: Align the bottom of the Eclipse™ Base Reflector with the chalk line.

Step 3: Secure Base to wall with 1 1/2" Pan-Head Walldog fasteners (provided).

⚠ Caution: Risk of Damage.

When attaching base to wall, do not overtighten screws.

Step 4: Tivoli recommends installing the second layer of carpet after the Eclipse base has been properly installed. Cut the carpet so the top edge just fits up behind the reflector section of Base. The finished edge should be located at the top edge of the carpet, as shown.

Step 5: The second layer of carpet **MUST** be installed evenly and smoothly below the fixture to prevent any warping or scalloping of the illumination.

Installation Instructions: Installing the Eclipse Base

Installing the Base Sections

Step 1: Eclipse™ Base should be installed 14" above floor. Begin by snapping a chalk line along the wall using the dimensions shown in the diagram below.

Step 2: Align the bottom of the Eclipse™ Base Reflector with the chalk line and use the chalk line to determine where to cut the Base Section to fit.

Note: Include space for Joiner Brackets and End Caps before starting to install Base Sections (See Spacing Requirements, Page 3).

Step 3: Drill 5/16" feed hole at start of run to route lead wire through wall, as shown. Hole must align with conduit, already installed in wall.

Step 4: Secure Base to wall with 1 1/2" Pan-Head Walldog fasteners (provided). Holes are pre-drilled at the factory and spaced 7 11/16" apart.

Note: Occasionally, a mounting surface will require metal screws. Self-Drilling Metal Screws are available from Tivoli® as an option. Request Part Number **TM-2-3/8**.

⚠ CAUTION! Risk of Damage.

When attaching base to wall, do not overtighten screws. Warping and scalloping will result.

Installing over Wall Carpet

When installing Eclipse Lighting System over a wall with carpet, be sure the carpet is securely attached to the wall, with no sagging or scalloping. Carpet that is not secured evenly will result in uneven illumination.

⚠ WARNING! Damage to Fixture.

When installing Eclipse™ over carpet, carpet must be even and smooth on wall, or fixture may not install evenly, resulting in unsatisfactory illumination and damage to fixture base may result.

If a second layer of carpet is used, install the second layer of carpet after Eclipse™ Base is in position and has been securely fastened to wall. Position the second layer of carpet behind the reflector portion of the Base. Do not push any extra carpet behind the Reflector, as it will distort the fixture and cause uneven illumination. Trim carpet so it just meets the fixture base. See illustration on Page 1.

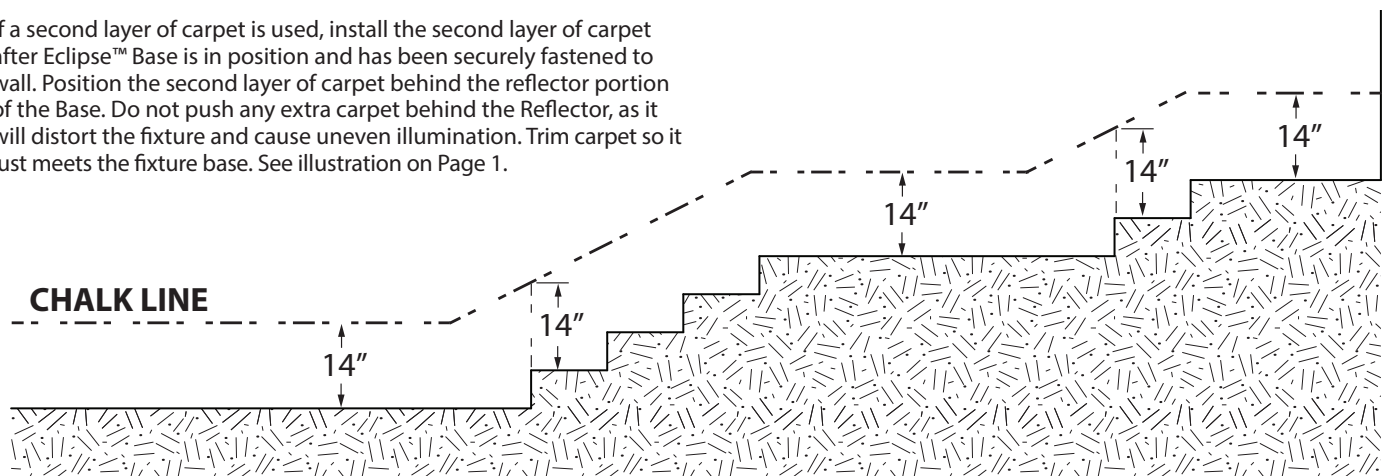
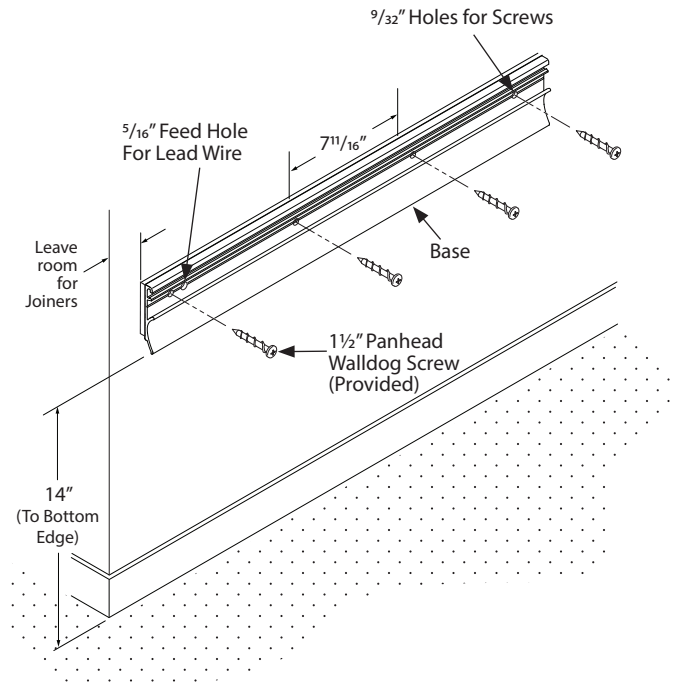

Spacing Requirements for Multiple Base Section Installation

In-Line Base Position

Step 5: To install multiple Base Sections in a line, use your chalk line to line up each section. Leave about 1/2" between each section to leave some room for the connectors. An In-Line Joiner will be used to cover the gap.

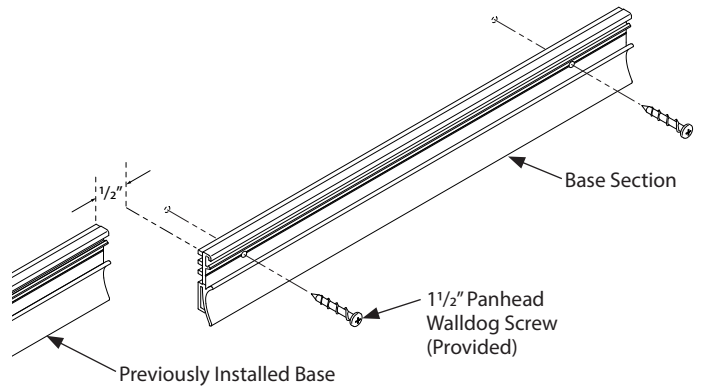

Upward Angle Base Postion

Step 6: Install upward angled Base Sections along stairways. Base Sections may be positioned at a 30°-35° angle to accomodate the Angled Joiner Brackets. Butt the top edge of Base Section against the top edge of the previously installed Base.

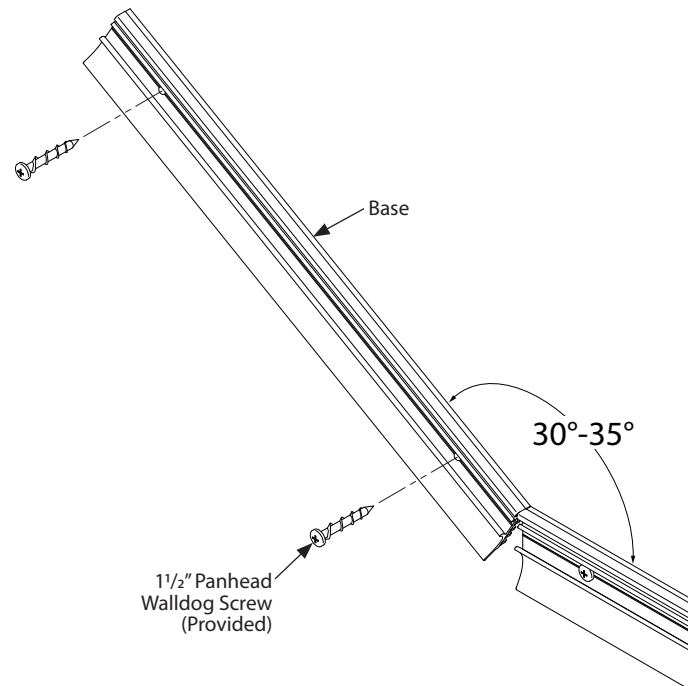

Downward Angle Base Position

Step 7: Install downward angled Base Sections at a 30-35 angle to accommodate the downward joiner Brackets. The bottom edge of the reflector may butt against the edge of the previously installed reflector, as shown.

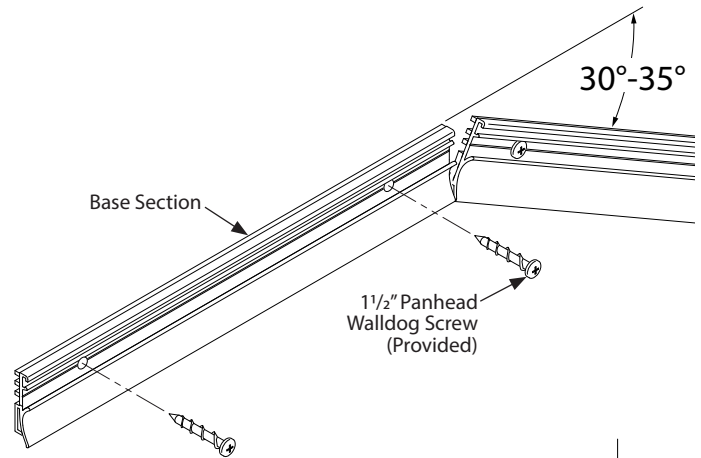

End Cap Location

Step 8: If the project calls for End Caps at the ends of the run, leave a 7/16" space at the end of the run to provide space for the End Cap Bracket. Leave 1 1/2" from an inside corner to allow room to insert End Cap tab into fixture.

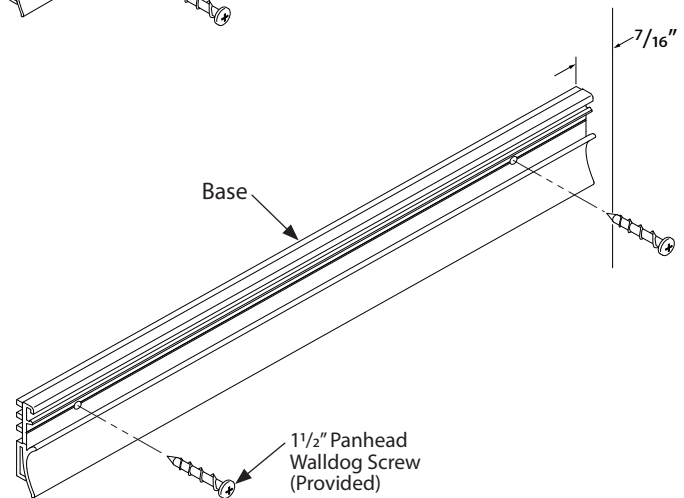

Outside Corner Position

Step 9: When two channels meet at an outside corner, use Outside Corner Covers to conceal the gap between sections. Leave a 3/4" space from the end of each Base Section to the corner to leave room for the Outside Corner Cover.

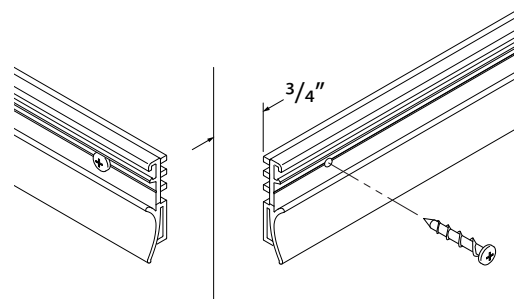

Inside Corner Position

Step 10: When two channels meet at an inside corner, use Inside Corner Covers to fill the gap between sections. Leave a 1 1/2" space from the end of each channel to the inside corner to make room for the Inside Corner Bracket.

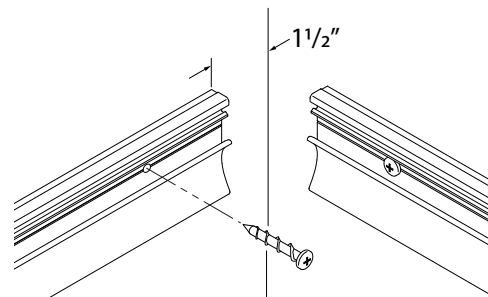

Spacing Requirements (Continued)

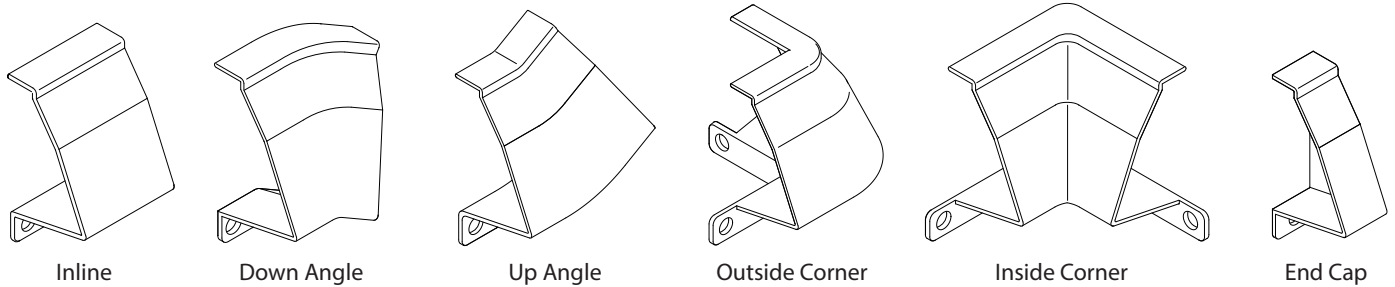

Note: Joiner Brackets are installed after the Eclipse Shields are in place. See Page 7 For Eclipse Shield Installation Instructions.

Typical Joiner Installation

Position the joiner over the gap between two Eclipse™ sections; either in-line, angled or at a corner. Secure with two 1½" Walldog screws (Provided).

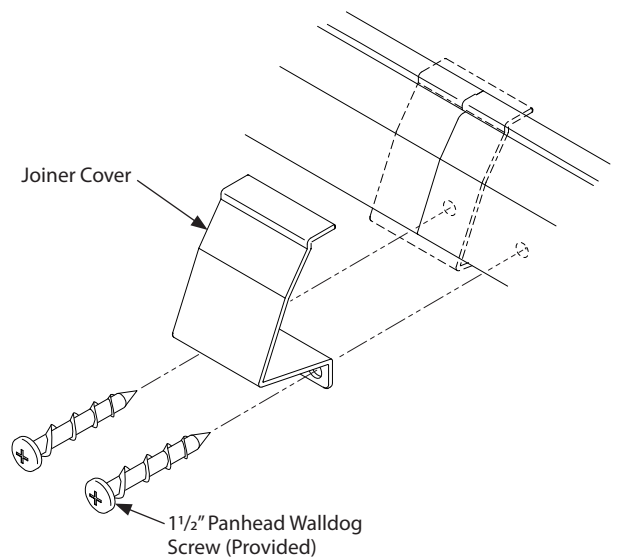

End Cap Installation

Position End Cap at End of Eclipse™ Section and Slide Tab between the Shield and Base, as shown. Be sure top edge of End Cap rests on top edge of Base and that it has been inserted as far as it will go. Secure with one 1½" Walldog Screw (Provided).

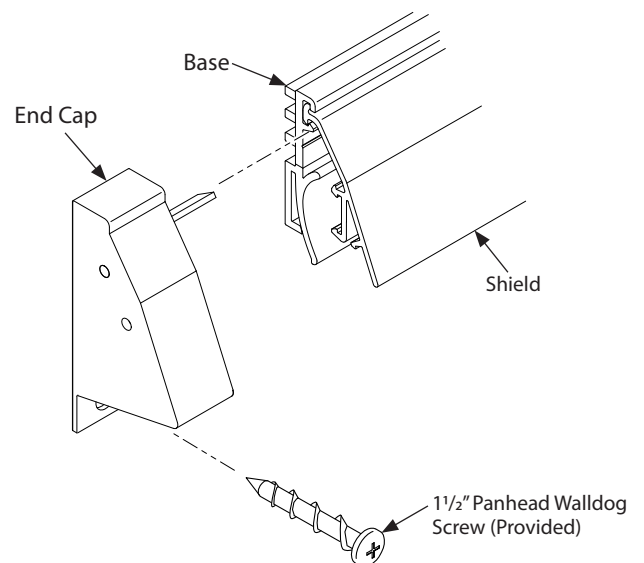

Wiring the System

The Eclipse™ Wall Lighting System is supplied with male and female bullet connectors attached at wire ends to facilitate interconnection of fixtures. Connect lead wires from Eclipse™ to power cables using mating male and female bullet connectors (18-22 ga). Maintain polarity by heeding the positive and negative identification labels on each wire. The smooth wire is Positive (+) and the ribbed wire is negative (-).

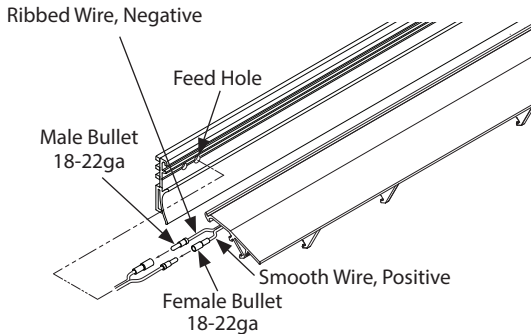

Product Specification Guide		
Eclipse™ Wall	Watts per Foot	Max Linear Run
1900°K-4000°K	1.15	56'
Red	1.53	48'
Blue	1.28	56'
Amber	1.23	56'
Dolby Blue	1.38	56'
Prime Red	1.62	48'
IMAX Blue	1.23	56'

Step 11: To complete wiring connections, feed the Lead wire through the feed hole in base and down inside the conduit to the Junction Box. Make connections using mating Bullet Connectors or wire nuts for 18-22ga wire. See Page 4 for wiring options.

⚠ WARNING! Danger of Electrical Shock. Be sure power is turned off before proceeding.

Wiring Options

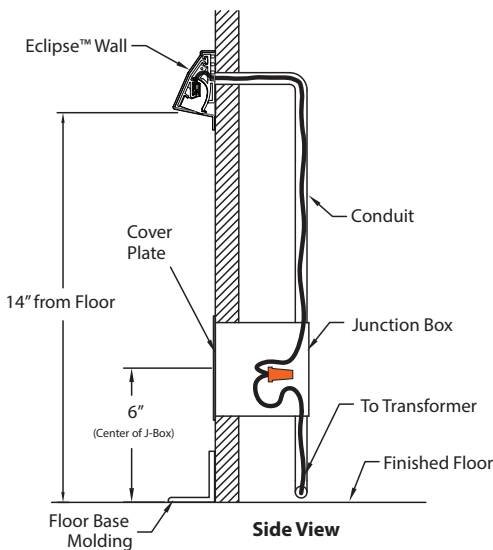

Eclipse™ Wall Light and J-Box Mounting Height

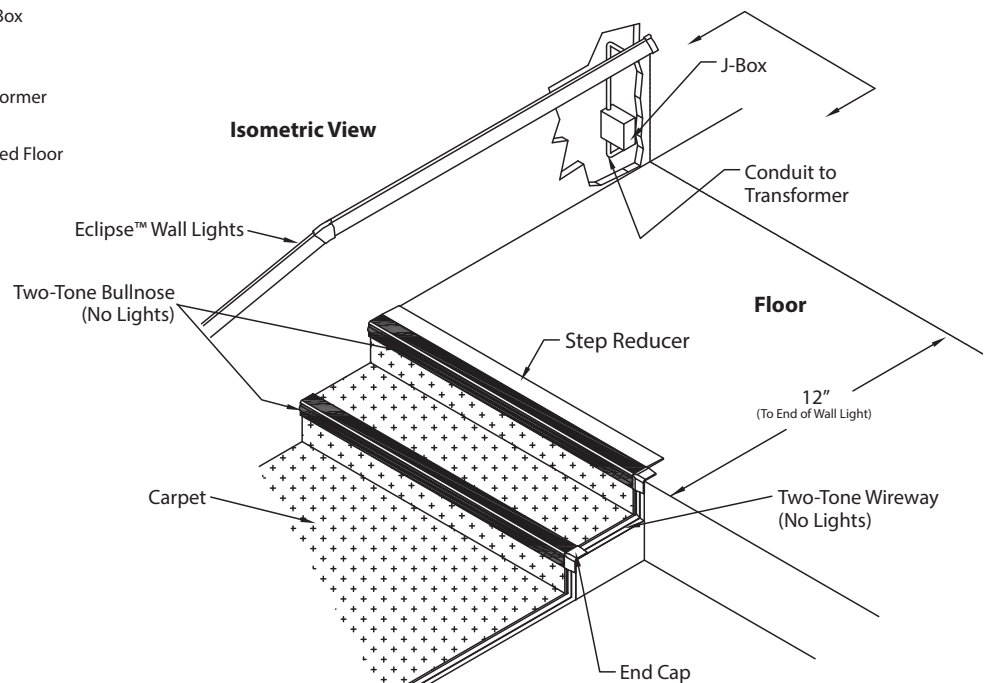

Preparing the Shield

Preliminary

If the Base Sections were field-trimmed to fit, the Shield Sections will need to be trimmed to matching lengths. Before cutting, uninstall the Titanium Modules from the area that will be cut off and move out of the way of the blade.

Disassemble Titanium Strand

Step 1: Start by removing the Baffle. Firmly grasp the lower area of the Baffle, as shown, and carefully pull it over the locking tab.

Step 2: Rotate Baffle until it is free and remove from Shield.

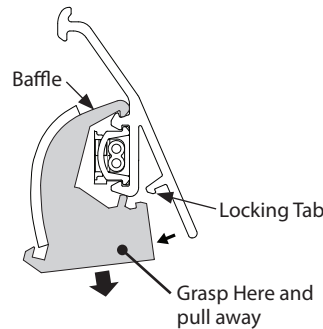
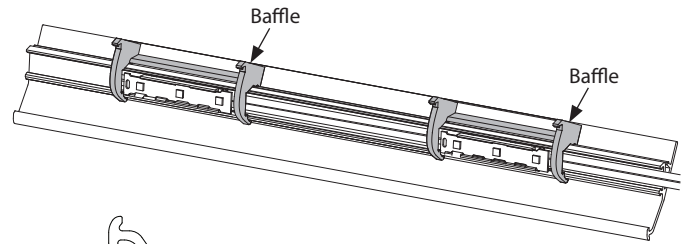

Step 3: Position Putty Knife between the LED module and the mounting channel. Gently pry LED module up and out of the channel.

Step 4: Repeat removal procedure for all excess modules.

Step 5: Measure the shield and mark at cut point. Move the LED module strand out of the way of the blade and cut Shield to match the length of the corresponding Base Section.

Step 6: Cut off the extra length of Titanium Strand making sure to leave enough lead to allow it to be connected to the next LED strand while taking note which type of connector (male or female) was attached to the smooth wire and the ribbed wire.

Step 7: Re-install LED module strand and baffles.

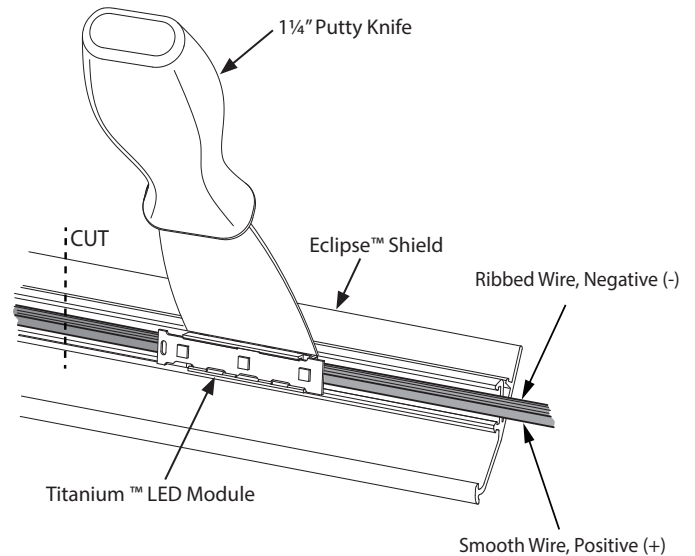

Step 8: Using a Crimping Tool, crimp a new connector onto the end of each wire that was cut to facilitate connection to the next Eclipse™ Section, taking care to install a connector of the same type, male or female, as the one that was previously removed. Extra Bullet-type connectors are included in kit.

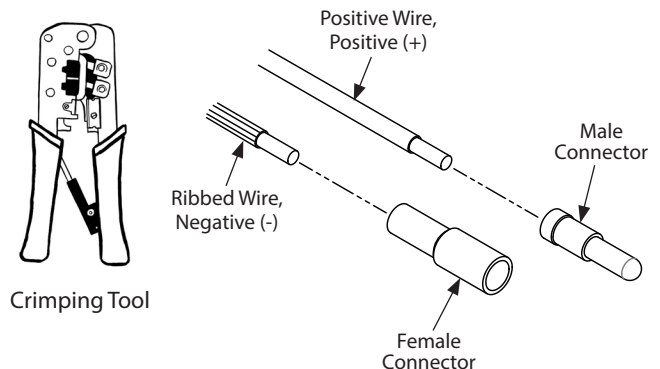

Installing the Shield

Overview

The Eclipse™ Wall System is supplied with male and female Bullet Connectors attached at wire ends to facilitate interconnection of fixtures. Connect multiple fixtures by joining male and female connectors together. Attach lead wires from unit to power cables using mating male and female Bullet Connectors (18-22ga). Alternatively, the connectors may be cut off to allow the wires to be joined together using wire nuts. The smooth wire is Positive (+) and the ribbed wire is negative (-). The available 24" jumper wire may be used to connect the fixture to the power supply.

Step 1: If used, attach the accessory lead wire to the lead end of the Titanium LED strand by connecting the mating connectors together.

Step 2: Feed the Lead wire through the feed hole in base and down the conduit to the Junction Box. See "Wiring The System", Page 5.

Step 3: Insert tab along top edge of Shield into slot along top of Base Section.

Step 4: Baffles are pre-assembled at the factory, but if they are removed, replace them before installing the shield. Place the top of baffle against upper locking tab and rotate the baffle downward until it snaps into place on the lower locking tab.

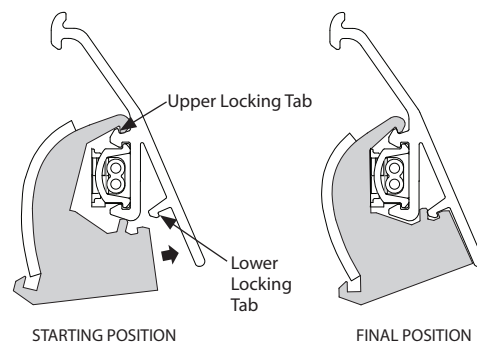
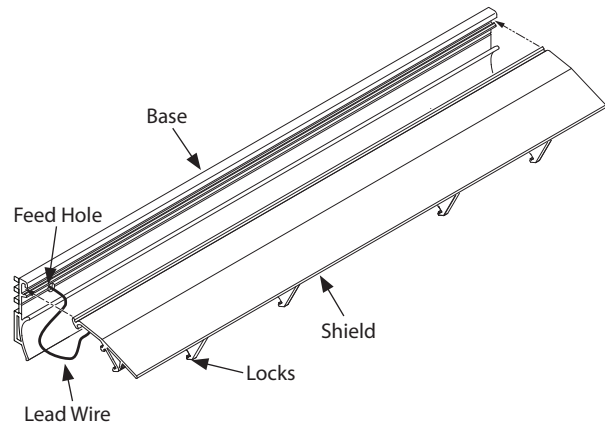
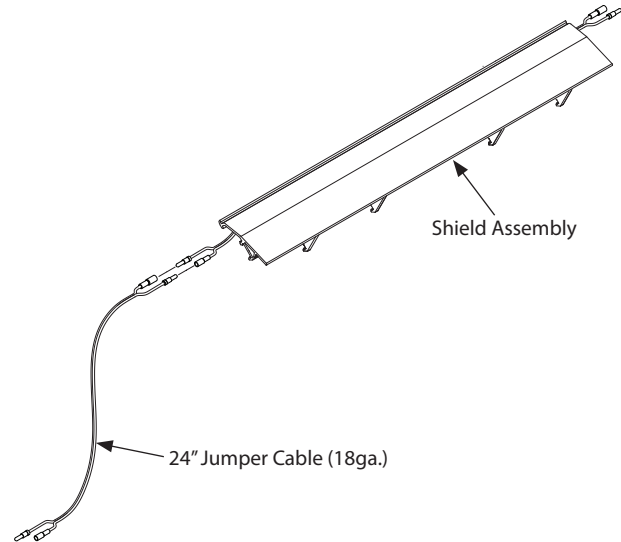

Installing the Shield (Continued)

Step 5: Rotate Shield down by pressing on one end until it snaps down into position. Continue pressing down along the length of the shield until it has snapped down into position along the entire length.

Step 6: Check along bottom edge of Shield to make sure all the locks have snapped into place. If any of the locks are not engaged, press down in that area until all locks at bottom edges of baffles have snapped into place, as shown.

Step 7: Interconnect the rest of the Shield Assemblies by connecting the Bullet Connectors from the end of the first assembly to the Connectors at the beginning of the next assembly.

Note: Occasionally, the clearance tolerance between a Shield and Base combination will cause a mating problem resulting in noticeable scalloping of the light pattern. If this occurs, swap the shield with another shield and this should resolve the problem.

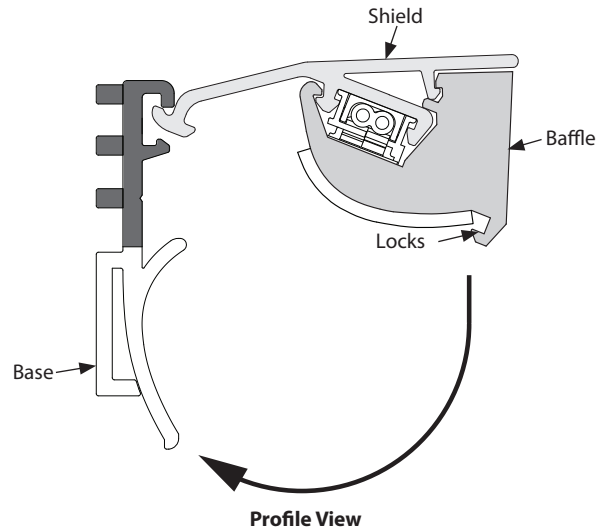

Step 8: Once all Shields are in place, install the Joiner Covers over joints, gaps, corners and End Caps. All covers install in the same manner. Place Joiner Cover over space between Eclipse™ segments. Rest the top of the Cover on the top surface of the Eclipse™ Base. Use two 1½" Walldog fasteners (provided) to attach Joiner Covers to mounting surfaces. End Caps attach to surface using only one screw. (For more information about Joiner Covers, see Page 5.)

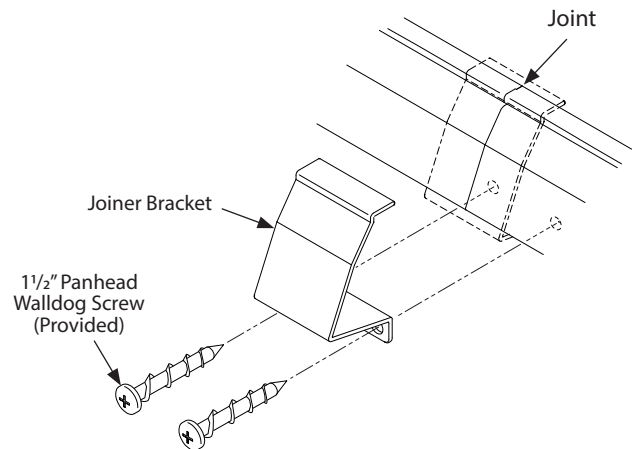

Eclipse Maintenance

Remove Shield for LED Strand Servicing

Step 1: Turn off power to the system.

Step 2: Remove Joiner Cover screws and remove Covers.

Step 3: Release Baffle Locks from underside of unit and rotate shield upwards. Place a finger behind lock and pull it away from Base.

Step 4: Remove the tab at the top of the Shield from the slot in the Base Channel.

Caution: The Shield will still be attached on either end by the strand lead wire so be careful not to rip out the wire unintentionally. Disconnect Bullet Connectors for easier servicing.

Step 5: Turn Shield over so the Titanium™ Module strand is visible for servicing.

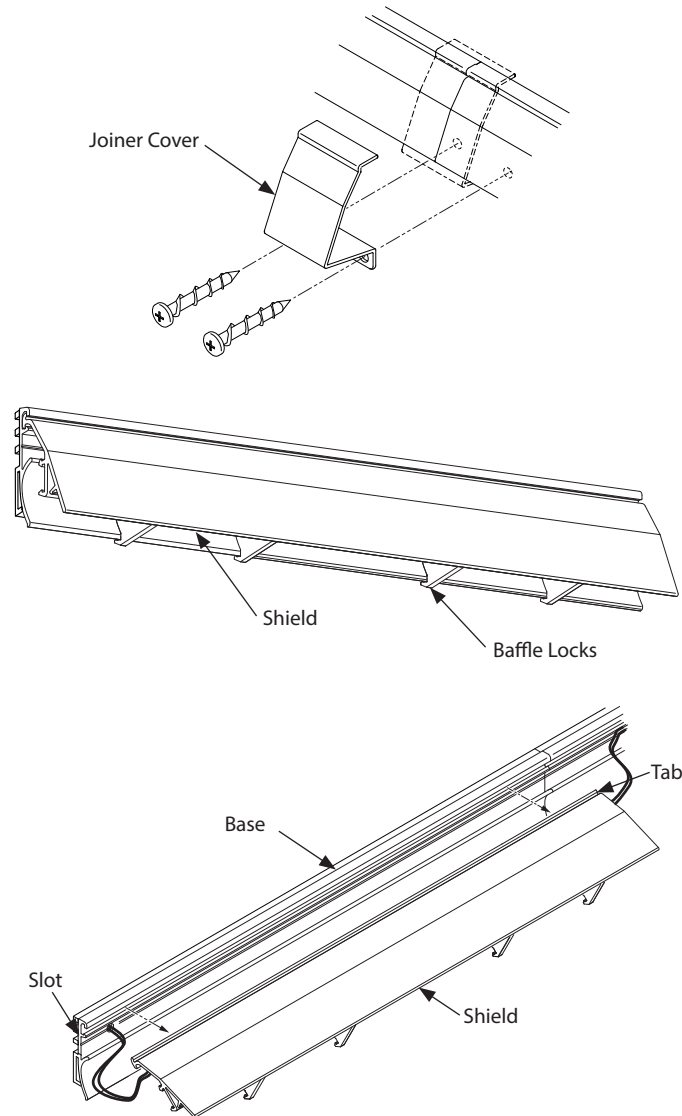

Removing and Installing the LED Board

Note: It is not necessary to remove the Baffle to access the LED Board.

Step 1: Slide board to the left as far as it will go. Insert a pointed object, such as a pen tip, into the slot at the end of the LED board to slide it more easily.

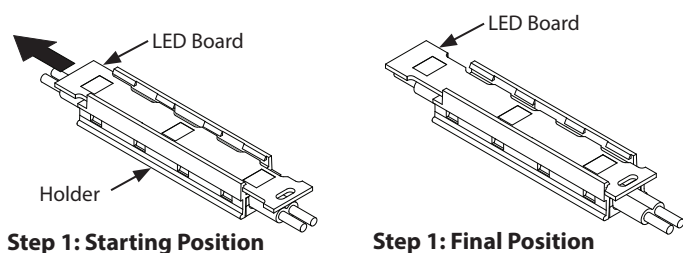

Step 2: Rotate top edge of board upward, as shown.

Step 3: Remove board.

Installation: Reverse steps to install.

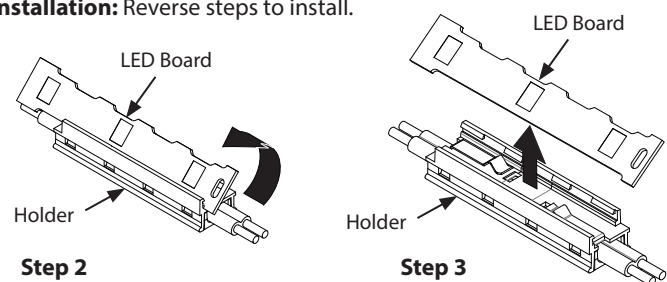

Eclipse Maintenance (Continued)

Replacing the LED Module Strand

Step 1: Firmly grasp the lower area of the baffle, as shown, and carefully pull over locking tab.

Step 2: Rotate baffle until it is free and remove from Shield.

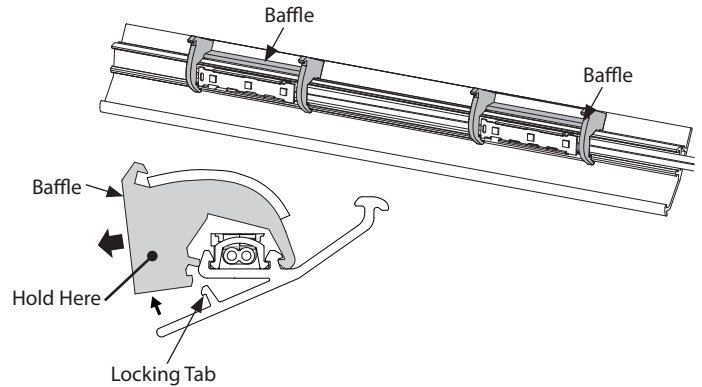

Step 3: Cut the wires outside of the defective portion of the light strand on either side, as shown.

Step 4: Position Putty Knife between the LED module and the mounting channel. Gently pry LED module up and out of the channel.

Step 5: Repeat removal procedure for all defective modules.

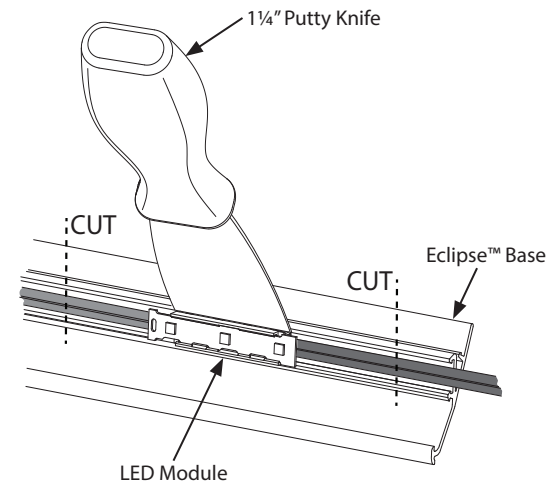

Install New LED Module

Step 6: Position replacement LED module in mounting channel with the mounting tab under the top ledge of the mounting channel, as shown.

Step 7: Rotate the module down until it makes contact with the lower ledge of the mounting channel. Position the Putty Knife on the lower mounting tab and continue to gently press the module into the channel until the lower mounting tab snaps into place under the lower ledge of the mounting channel.

Step 8: Repeat installation process for all new modules in the strand.

Step 9: Use Butt Connectors (TV5250007) for 18ga wire to connect the wiring on the replacement strand to the existing strand wiring.

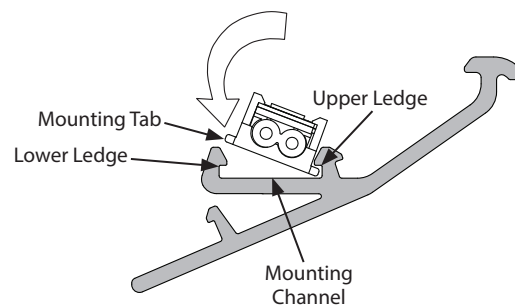

Step 10: Replace Baffles. Place top of baffle against upper locking tab and rotate the baffle downward until it snaps into place on the lower locking tab.

Step 11: Re-insert the Shield into the Tab at the top of The Base Channel and rotate into position. Be sure the Baffle Clips lock the Shield in place.

Step 12: Re-establish power to the lighting system.

